



## FIRE RESISTANCE

Fire Resistance Requirements in Australia, and how to choose the right EWPA Certified Product to Comply with the BCA

# Table of Contents

<b>Introduction .....</b>	<b>3</b>
<b>BCA and Fire Resistance .....</b>	<b>4</b>
Complying with the BCA.....	4
BCA Requirements .....	4
Designing for Fire Resistance .....	5
Notes .....	5
BCA Building Classes.....	6
<b>Class 2 – 9 Properties of Floor Material and Coverings.....</b>	<b>7</b>
<b>Class 2 – 9 Properties of Wall and Ceiling Linings .....</b>	<b>8</b>
<b>Class 2 – 9 Properties of Other Materials.....</b>	<b>10</b>
Untreated Plywood .....	10
Timbers and Plywoods Impregnated with Fire Retardants .....	11
<b>Class 1 and 10 Properties .....</b>	<b>12</b>
External Walls.....	12
Bushfire Areas .....	13
<b>Fire Resistance Levels .....</b>	<b>14</b>
<b>Early Fire Hazard Indices – An Older Standard .....</b>	<b>15</b>
Untreated Plywood .....	15
Timbers and Plywoods Treated with Fire Retardants .....	16
<b>Thermal Properties of Plywood.....</b>	<b>17</b>
Thermal Expansion .....	17
Thermal Conductivity .....	17
Thermal Resistance .....	17
Thermal Performance of Timber Framed Plywood Clad Walls .....	17
Improving Plywood Thermal Performance .....	18
<b>Exposure to Extreme Heat .....</b>	<b>19</b>
<b>Technical Explanations.....</b>	<b>20</b>
<b>Revision History.....</b>	<b>22</b>

## Introduction

Three components are required for a fire, i.e. fuel, heat and oxygen. This knowledge is essential when considering containment which requires eliminating one of these three components from the other two. That is, to extinguish the fire requires removing:

- heat by wetting;
- fuel by eliminating the source;
- oxygen by smothering the fire.

Wood is composed of a mixture of cellulose, hemicellulose, and lignin bound together in a complex network. Heating wood above 280°C causes decomposition or pyrolysis converting it to gases, tar and charcoal. At temperatures above 280°C the gases will flame vigorously but the charcoal requires temperatures of about 500°C for its consumption. A build-up of char tends to protect the unburnt wood from rapid pyrolysis. The unburnt timber, being a good insulator, results in the timber close to the char edge being unaffected by the fire. Figure 1 shows a schematic representation of burning wood.

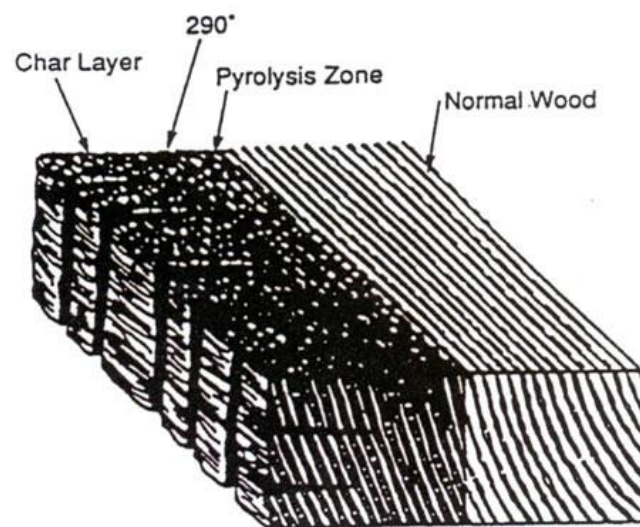

Figure 1 : Shows zones of burning wood

Fire Resistance refers to the ability of a building component to resist a fully developed fire, while still performing its function.

# BCA and Fire Resistance

The Building Code of Australia (BCA) is a uniform set of technical provisions for the design and construction of buildings and other structures throughout Australia. This document includes a section on Fire Resistance, and designers and builders must ensure that their constructions satisfy this section.

## Complying with the BCA.

The BCA document is a “Performance” based requirements document. This refers to the fact that requirements are stated in terms of performance, and designers and builders must ensure that the performance criteria are met in their constructions. Note that this is very different from prescriptive requirements which state “how” one must achieve the desired requirement.

**Example :**  
Prescriptive : The beam shall be steel, and 3.5 meters long  
Performance: The beam shall be able to support 1000Kg, with no more than 5mm deflection.

In the above, one can see how the second requirement allows for multiple solutions, while the first requirement only allows for 1 solution.

## BCA Requirements

In order to comply with BCA, one must do one of the following :

1. Comply with the “Deemed to Satisfy” provisions (which are sections in the BCA which lists ways that one can satisfy the performance criteria).
2. Formulate an alternative solution, that
  - a. complies with the performance criteria, or
  - b. is shown to be at least equivalent to the “Deemed to Satisfy” provisions.

The following lists the appropriate sections in the BCA for fire resistance :

Reference	Description
Section C	Fire Resistance section of the BCA.
Section C1	“Deemed to Satisfy” provisions regarding fire resistance and stability.
Section C1.10	“Deemed to Satisfy” provisions for Fire Hazard Properties of materials.
Specification C1.10	“Deemed to Satisfy” requirements for materials other than floors, walls and ceilings.
Specification C1.10a	“Deemed to Satisfy” requirements for floors, walls and ceilings.

## Designing for Fire Resistance

In order to determine the correct type of plywood for your design / construction project, you should complete the following steps :

**Step 1.** Determine the class of building ([click here](#)).

**Step 2.** Determine which BCA requirement is applicable :

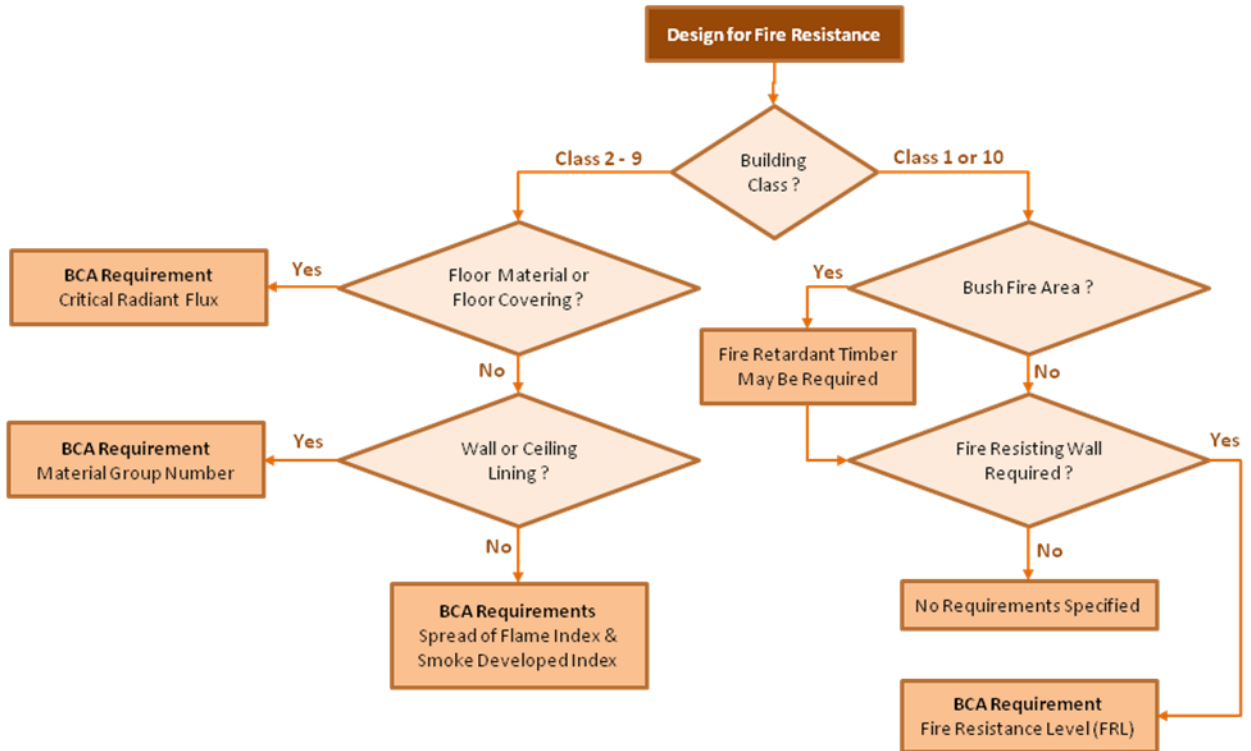

**Step 3.** Choose plywood that meets these requirements.

The remainder of this document will guide the reader through the above steps.

## Notes

When using this document for guidance, please take note of the following :

1. The BCA must be consulted to determine all of the requirements applicable to your design / construction project.
2. Note that in the 2007 version of the BCA, section C1.10, clause (b) states that "Paint or fire retardant coatings must not be used to make a substrate comply with the required fire hazard properties."

**However, plywood products that have been impregnated with fire retardant under high pressure, are acceptable in achieving the required hazard properties.**

## BCA Building Classes

The various classes of buildings are described in the Part A3 of the BCA 2007 document, and are copied here for convenience :

Class	Definition
<b>Class 1a</b>	A single dwelling being – (i) A detached house; or (ii) One of a group of 2 or more attached dwellings, each being a building, separated by a fire resisting wall, including a row house, terrace house, town house or villa unit.
<b>Class 1b</b>	A boarding house, guest house, hostel or the like – (i) with a total area of all floors not exceeding 300 m <sup>2</sup> measured over the enclosing walls of the Class 1b; and (ii) in which not more than 12 persons would ordinarily be resident.
<b>Class 2</b>	A building containing 2 or more sole-occupancy units each being a separate dwelling.
<b>Class 3</b>	A residential building, other than a building of Class 1 or 2, which is a common place of long term or transient living for a number of unrelated persons, including – (a) a boarding house, guest house, hostel, lodging house or backpackers accommodation; or (b) a residential part of a hotel or motel; or (c) a residential part of a school; or (d) accommodation for the aged, children or people with disabilities; or (e) a residential part of a health-care building which accommodates members of staff; or (f) a residential part of a detention centre.
<b>Class 4</b>	A dwelling or building that is class 5,6,7,8, or 9 if it is the only dwelling in the building
<b>Class 5</b>	An office building used for professional or commercial purposes, excluding buildings of class 6,7,8, or 9.
<b>Class 6</b>	A shop or other public building for the sale of goods by retail or the supply of services direct to the public, including – (a) an eating room, café, restaurant, milk or soft drink bar; or (b) a dining room, bar, shop or kiosk part of a hotel or motel; or (c) market or sale room, show room or service station.
<b>Class 7a</b>	A building which is a car park.
<b>Class 7b</b>	A building which is for storage, or display of goods or produce for sale by wholesale.
<b>Class 8</b>	A laboratory or a building in which a handcraft or process for the production, assembling, altering, repairing, packing, finishing, or cleaning of goods or produce is carried on for trade sale or gain.
<b>Class 9a</b>	A building of a public nature that is a health care building, including those parts of a building set aside as a laboratory.
<b>Class 9b</b>	An assembly building, including a trade workshop, laboratory or the like in a primary or secondary school, but excluding any other parts of the building that are of another class.
<b>Class 9c</b>	An aged care building.
<b>Class 10a</b>	A non-habitable building being a private garage, carport, shed, or the like.
<b>Class 10b</b>	A structure being a fence, mast, antenna, retaining or free standing wall, swimming pool, or the like.

## Class 2 – 9 Properties of Floor Material and Coverings

Specification C1.10a of the BCA 2007 states that a floor material or floor covering must have :

- A **Critical Radiant Flux (CRF)** not less than that listed in the table below; and
- A maximum **Smoke Development** rate of 750 percent-minutes, if the building is not protected by a sprinkler system complying with Specification E1.5 of the BCA 2007.

Class of Building	General		Fire-Isolated Exits
	Building not fitted with a sprinkler system complying with Specification E1.5	Building fitted with a sprinkler system complying with Specification E1.5	
<b>Class 2,3,5,6,7,8 or 9b</b> Excluding accommodation for the aged	2.2	1.2	2.2
<b>Class 3</b> Accommodation for the aged	4.5	2.2	4.5
<b>Class 9a</b> Patient care areas Areas other than patient care areas	4.5	2.2	4.5
	2.2	1.2	4.5
<b>Class 9c</b> Resident use areas Areas other than resident use areas	-	2.2	4.5
	-	1.2	4.5

**Table 1 : Critical Radiant Flux (CRF in kW/M<sup>2</sup>) of Floor Materials and Floor Coverings**

For a technical explanation of Critical Radiant Flux, refer to the [Technical Explanations](#) section.

The following table\* provides the most recent available data on Critical Radiant Flux testing, and can be used in selecting a suitable plywood for floor materials and coverings.

Note that when plywood flooring from the table below is used, the plywood must be solid plywood made from the species listed, fixed to structural framing with an air gap behind, and can incorporate a PVC tongue profile, and be of smooth milled surface finish.

Species	Thickness	CRF	Smoke Development Rate
Pine, Hoop – <i>Araucaria cunninghamii</i>	15mm or greater	Between 2.2 and 4.5	Less than 750 percent-minutes
Pine, Radiata – <i>Pinus Radiata</i>	17mm or greater		
Pine, Slash – <i>Pinus Elliottii</i>	17mm or greater		

\*The data in this table was sourced from a Warrington Fire Research Report, available from the EWPAA on request.

## Class 2 – 9 Properties of Wall and Ceiling Linings

In order to design wall or ceiling linings with plywood, the Material Group number applicable to the design / construction must be determined, then a plywood product with that material group number is selected.

Group 1 materials are suitable for the most stringent fire hazard requirements whilst Group 4 do not meet the requirements for lining materials for walls and ceilings.

For a technical explanation of the Material Group Number, refer to the [Technical Explanations](#) section.

Table 2 of BCA 2007 Specification 1.10(a) gives Deemed-to-Satisfy Provisions for wall and ceiling lining materials, in terms of Material Group Numbers, for sprinklered and unsprinklered buildings, and is reproduced here for convenience :

Class of Building	Fire-isolated exits Wall/ceiling	Public corridors		Specific Areas		Other areas Wall/ceiling
		Wall	Ceiling	Wall	Ceiling	
<b>Class 2 or 3, Excluding accommodation for the aged, people with disabilities, and children</b>						
Unsprinklered	1	1,2	1,2	1,2,3	1,2,3	1,2,3
Sprinklered	1	1,2,3	1,2,3	1,2,3	1,2,3	1,2,3
<b>Class 3 or 9a, Accommodation for the aged, people with disabilities, children and health-care buildings</b>						
Unsprinklered	1	1	1	1,2	1,2	1,2,3
Sprinklered	1	1,2	1,2	1,2,3	1,2,3	1,2,3
<b>Class 5,6,7,8 or 9b schools</b>						
Unsprinklered	1	1,2	1,2	1,2,3	1,2	1,2,3
Sprinklered	1	1,2,3	1,2,3	1,2,3	1,2,3	1,2,3
<b>Class 9b other than schools</b>						
Unsprinklered	1	1	1	1,2	1,2	1,2,3
Sprinklered	1	1,2	1,2	1,2,3	1,2,3	1,2,3
<b>Class 9c</b>						
Sprinklered	1	1,2	1,2	1,2,3	1,2,3	1,2,3
For the purpose of this Table: 1. "Sprinklered" means a building fitted with a sprinkler system complying with Specification E1.5. 2. "Specific areas" means within: (a) for Class 2 and 3 buildings, a <i>sole-occupancy unit</i> . (b) for Class 5 buildings, open plan offices with a minimum floor dimension/floor to ceiling height ratio >5. (c) for Class 6 buildings, shops or other building with a minimum floor dimension/floor to ceiling height ratio >5. (d) for Class 9a <i>health-care buildings, patient care areas</i> . (e) for Class 9b <i>theatres and halls, etc. an auditorium</i> . (f) for Class 9b <i>schools, a classroom</i> (g) for Class 9c aged care buildings, resident use areas.						

**BCA Specification C1.10a, Table 2 : Wall and Ceiling Lining Materials (Material Groups Permitted)**



Plywood Species	Minimum Thickness (mm)	Group No.	Average Specific Extinction Area (m <sup>2</sup> /kg)
Pine, Radiata – Pinus Radiata *	6mm or greater	3	< 250
Lauan – Shorea agsaboensis *	6mm or greater	3	< 250
Pine, Hoop ⊥	6mm or greater	3	82.4
Pine, Slash ⊥	6mm or greater	3	96.0

\* Information from a Warrington Fire Research (Aust) Pty Ltd Report No. 45980 on “Assessment of Solid Timber, Plywood & Timber Veneers on MDF and Particleboard for use as Wall & Ceiling Lining with respect to the Building Code of Australia Specification C1.10a.” for the Timber Development Association, Sydney, 2006 gave the above results for plywood.

⊥ Information supplied from CSIRO reports numbered FNK 9157 and FNK 9156. Samples were tested in accordance with AS/NZS 3837 at 50 kW/m<sup>2</sup> irradiance.

## Class 2 – 9 Properties of Other Materials

Specification C1.10 of the BCA 2007 states that Materials used in buildings of Class 2 – Class 9 must :

- Have a **Spread of Flame Index** of not more than 9; and
- Have a **Smoke Developed Index** of not more than 8, if the **Spread of Flame Index** is more than 5.

For a technical explanation of the Spread of Flame Index and the Smoke Developed Index, refer to the [Technical Explanations](#) section.

The following tables can be used in selecting a suitable plywood for materials other than floors, walls or ceilings.

The table provides the most recent available data on early fire hazard test data for both untreated and fire retardant impregnated plywood. To obtain current information on this topic the designer is referred to companies involved in fire retardant treatment or contact EWPA.

### Untreated Plywood

Face Veneer Common Name	Botanical Name	Spread of Flame Index (0-10)	Smoke Developed Index (0-10)
Ash, Hickory (grooved)	Flindersia iffliana	8	3
Ash, Silver	Flindersia bourjotiana	8	3
Ash, Victorian	Mixture of Euc. Regnans, Euc. delegatensis	8	2
Australian Red Cedar	Toona australis	9	9
Australian Red Cedar (grooved)	Toona australis	8	2
Blackbean	Castanospermum australe	9	3
Blackbutt*	Eucalyptus pilularis Sm.	7	3
Coachwood	Ceratopetalum apetalum	8	2
Gum, Rose*	Eucalyptus grandis	8	3
Gum, Spotted*	Corymbia maculate	8	3
Klinkii pine	Aurancaria hunsteinii	8	4
Lauan	Parashorea Spp. Shorea Spp.	8	3
Meranti	Shorea Spp.	8	2
Pacific Maple	Shorea Spp.	8	2
Pine, Hoop*	Araucaria cunninghamii	9	3
Pine, Radiata	Pinus radiata	8	2
Pine, Radiata (scorched and brushed surface)	Pinus radiata	7	2
Pine, Slash*	Pinus elliotii	8	3
Queensland Maple	Flindersia brayleyana	8	2
Queensland Walnut	Endiandra palmerstoni	8	3
Sapele	Entandrophragma cylindricum	8	2

\*Information sourced from <http://www.timber.net.au>, which is published by the Timber Development Association of New South Wales, Australia.

## Untreated Plywood (Cont.)

Face Veneer Common Name	Botanical Name	Spread of Flame Index (0-10)	Smoke Developed Index (0-10)
Tasmanian Oak	Mixture of Euc. obliqua, Euc. Delegatensis, Euc. regnans	8	2
Teak	Tectona grandis	8	3
Victorian Ash	Mixture of Euc. Regnans, Euc. delegatensis	8	2

## Timbers and Plywoods Impregnated with Fire Retardants

Timber Species	Treatment	Spread of Flame Index (0-10)	Smoke Developed Index (0-10)
Hoop Pine	Retardant Impregnated	0	2
Yellow Walnut	Retardant impregnated	0	1

REFERENCES: (a) \*'Early Burning Properties of Australian Building Timber', J. Beesley, J.J. Keogh, A.W. Moulen, Division of Building Research Technical Paper No. 6 24 pages published by C.S.I.R.O. 1974

The contents of this publication may be reproduced provided acknowledgement is made to the Timber Development Association (N.S.W.) Ltd. Extracts should not be published without prior reference to T.D.A.

## Class 1 and 10 Properties

Class 1 buildings are generally residential dwellings, and Class 10 buildings are structures such as car ports and other non-inhabited buildings that usually accompany a residential type house.

### External Walls

Section 3.7.1 from the BCA Volume Two document, states that external walls that are required to be fire resisting, must have an Fire Resistance Level (FRL) of 60/60/60. Walls that are required to be fire resisting are :

- (a) 900mm from an allotment boundary other than the boundary adjoining a road alignment or other public space; or
- (b) 1.8m from another building on the same allotment other than an accompanying Class 10 building or a detached part of the same Class 1 building.

For details on FRL's, see the [Fire Resistance Level](#) section.

Walls other than those above do not have to be fire resisting. This means that plywood and LVL may be used anywhere on the external wall of a residential dwelling that is not required to be fire resisting. On walls that are required to be fire resisting, Plywood on its own cannot meet a level of 60/60/60.

However, in 2001, the National Timber Development Council has detailed a method of achieving a 90/90/90 FRL, entitled "External 90/90/90 Fire Rated Plywood Faced Wall System". This system is as follows :

#### EXTERNAL LIGHTWEIGHT CLAD WALL - NAIL LAMINATED POST SYSTEM

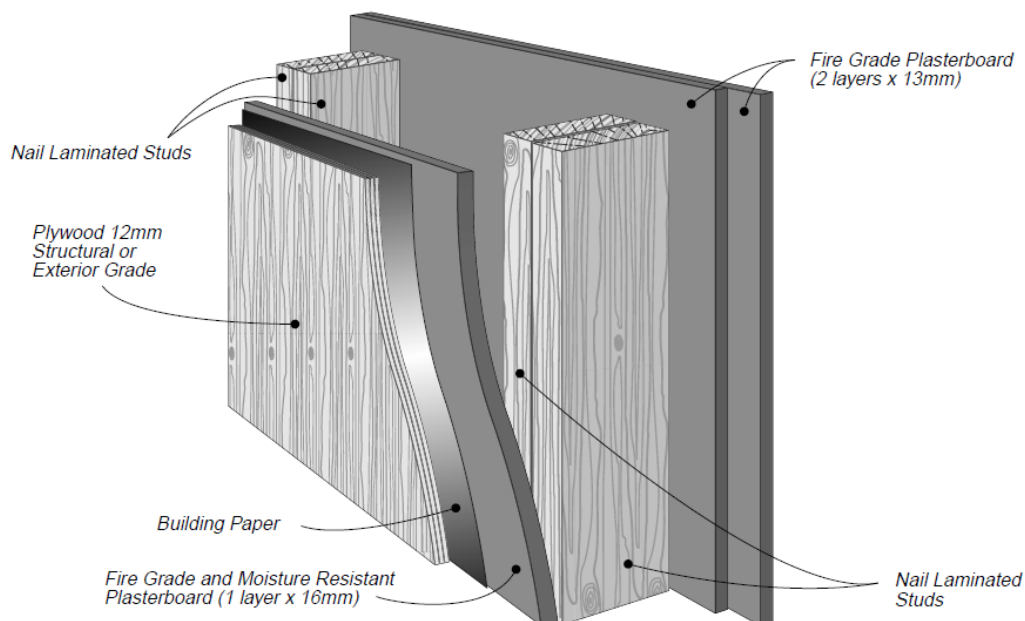

In the above diagram the studs are laminated together because generally, the size of the studs required for fire resistance is double the thickness of studs required to support normal structural loads.

## Bushfire Areas

Section 3.7.4 of the BCA specifies requirements for Class 1 buildings situated in designated bushfire prone areas. These specifications are summarised below :

	Bushfire Attack Category		
	Medium	High	Extreme
<b>Timber Bearers, Joists, Flooring, Verandahs and Decks</b>			
>= 600mm above ground	No Treatment Required	No Treatment Required	If floor is not enclosed, Fire Retardant Treated, or sheeted underneath with a non-combustible material.
< 600mm above ground	Fire Retardant Treated	Fire Retardant Treated	Fire Retardant Treated
<b>Sheet Cladding as External Walls</b>			
> 400mm above ground	No Treatment Required	Fire Retardant Treated	Fire Retardant Treated
<= 400mm above ground	Fire Retardant Treated, or covered by or substituted with non-combustible material.	Fire Retardant Treated	Fire Retardant Treated

## What does Fire Retardant Treated Mean ?

Fire Retardant Treated timber is timber that is tested and yields results that are in accordance with BCA 3.7.4.3. Designers that require Fire Retardant Treated timber for their design must ensure that the treatment is in accordance with this clause.

## How do you determine the Bushfire Attack Category ?

The determination of the bushfire attack category must be in accordance with the Australian Standard AS 3959 – “Construction of Buildings in Bushfire Prone Areas”. Issues such as distance from vegetation, type of vegetation and slope of the land must be taken into account. AS 3959 states different methods for calculating the bushfire attack category, depending on which state the building will be situated in. Designers should contact local governments to determine the bushfire attack category.

Note that these requirements **are additional** to all other requirements that apply to constructions in non-bushfire prone areas.

## Fire Resistance Levels

Fire Resistance is the ability of a building component to resist a fully developed fire, while still performing its structural function. Fire resistance levels (FRL) are assigned as performance criteria, in minutes, for structural adequacy, integrity and insulation. This important parameter is defined by three numbers, e.g. 30/30/30 for which the:

- first number relates to structural stability, i.e. the time to elapse before collapse;
- second number is an integrity requirement, i.e. flames must not pass through the component for this number of minutes;
- third number is an insulation value, i.e. limits heat transfer through the component.

Plywood is quite acceptable as a material used in fire resistant components provided it is combined with other materials so as to meet the fire resistant requirements. This can be achieved by combining plywood with non-combustible materials such as fibrous cement or fire grade plasterboard. The FRL rating is evaluated in a Standard Fire Test as specified in AS 1530.4.

LVL beam or column components can be assessed for fire resistance levels as per the requirements of AS 1720.4 Timber Structures – Fire-resistance of structural timber members. To ascertain the retained load carrying capabilities of a structural element is done through a fire resistance test. This assesses how long a component can continue to perform when exposed to a fire. This ability is measured in terms of the elapsed time to failure.

When establishing the Fire Resistance Level (FRL) of structural untreated wood and wood based products the charring rate of the surface is very important. As previously mentioned charring produces a protective layer which slows down the charring process. The unburnt timber can then be used in calculations to determine the structural integrity of the load bearing member.

The following table provides comparative data for fire resistance levels for structural stability between Douglas fir plywood as published in the Fire Protection Handbook published by the National Fire Protection Association, USA and radiata pine plywood as published by Carter Holt Harvey in their Technical Note 95/3/14, March, 1995.

Rating (Minutes)	Plywood Thickness for:		
	Douglas fir (USA) (mm)	Comparable Radiata Pine (mm)	Recommended Radiata Pine (mm)
10	6.4	7	12
15	9.5	12	12
20	12.7	15	17
25	15.9	17	21
30	19	19	25

The thicker Radiata pine panels are based on a char rate of 0.8mm per minute as opposed to the comparable thicknesses to the Douglas fir plywood having a char rate of 0.65mm per minute.

For an example on how to calculate a FRL, refer to the [Technical Explanations](#) section.

## Early Fire Hazard Indices – An Older Standard

The most dangerous period with regards to human safety is usually at the initial stages of the fire prior to flashover. Hence the need for provisions in the BCA which limit the spread of fire and the development of smoke until the building occupants have time to evacuate. Tests have been developed which simulate a fire in a building or are done on test specimen to facilitate the generation of relevant design data.

Early fire hazard tests to AS 1530 Part 3 (which has now been superseded by ISO 9239.1, ISO 9705 and AS/NZS 3837 see Figure 16.2) were performed to assess the surface burning characteristics of materials. The data generated through these tests is still valid for sarking type materials, i.e. reflective foil or other flexible membranes for waterproofing, vapour proofing or thermal reflectance. However, it does not apply to floor materials and floor coverings, nor wall and ceiling linings fire hazard properties.

The test sample parameters quantified in the AS 1530 Part 3 test are:

- tendency to ignite through assigning an ignitability index;
- tendency to propagate flame through assigning a spread of flame index;
- ability to release heat once ignited through assigning a heat evolved index;
- tendency to produce smoke while burning through assigning a smoke developed index.

The Early Fire Hazard Index is a measure of the plywood's surface characteristics relating to spread of flame, heat evolved, smoke emission and ignition. A low index value indicates better early fire hazard properties ( from best 0 to worst 20 for ignitability index and from 0 best to 10 worst for the others.)

Plywood possesses early fire hazard indices (13 – 15 depending on species - refer to the following table for details) which enable it to be used untreated in most applications. Plywood is suitable for use in most building linings, walls, ceilings, partitions and floors. Building codes may restrict its use in areas of severe hazard such as flues, hearths, public exits, public corridors, lift wells and certain enclosed public areas and buildings.

Treatment of plywood by impregnation with fire retardant salts, to reduce the early fire hazard indices, is permissible, provided appropriate certification is achieved showing compliance with the building regulations.

The use of in-tumescent finishes and paints to reduce the early fire hazard indices is not acceptable under current building regulations.

### Untreated Plywood

Face Veneer Common Name	Botanical Name	Ignitability Index (0-20)	Heat Evolved Index (0-10)
Australian Red Cedar	Toona australis	13	9
Australian Red Cedar (grooved)	Toona australis	13	7
Blackbean	Castanospermum australe	13	10
Coachwood	Ceratopetalum apetalum	15	8
Hickory Ash (grooved)	Flindersia ifflaiana	13	9
Klinkii pine	Aurancaria hunsteinii	15	10
Lauan	Parashorea Spp., Shorea Spp.	14	10
Meranti	Shorea Spp.	14	10
Pacific Maple	Shorea Spp.	14	10
Queensland Maple	Flindersia brayleyana	13	8

Face Veneer Common Name	Botanical Name	Ignitability Index (0-20)	Heat Evolved Index (0-10)
Queensland Walnut	Endiandra palmerstoni	14	10
Radiata Pine	Pinus radiata	14	9
Radiata Pine (scorched and brushed surface)	Pinus radiata	14	7
Sapele	Entandrophragma cylindricum	13	8
Silver Ash	Flindersia bourjotiana	13	9
Tasmanian Oak	Mixture of Euc. Oblique, Euc. Delegatensis, Euc. regnans	14	8
Teak	Tectona grandis	14	10
Victorian Ash	Mixture of Euc. Regnans, Euc. delegatensis	14	8

## Timbers and Plywoods Treated with Fire Retardants

Timber Species	Treatment	Ignitability Index (0-20)	Heat Evolved Index (0-10)
Hoop Pine	Retardant Impregnated	0	0
Redwood	Surface coated with 3 coats of fire retardant	14	4
	Surface coated with 1 coat of fire retardant	14	6
Western	Surface Coated with 3 coats of fire retardant	14	5
Red Cedar	Surface coated with 1 coat of fire retardant	15	6
Yellow Walnut	Retardant impregnated	0	0

REFERENCES: (a) \*\*Early Burning Properties of Australian Building Timber\*\*, J. Beesley, J.J. Keogh, A.W. Moulen, Division of Building Research Technical Paper No. 6 24 pages published by C.S.I.R.O. 1974

The contents of this publication may be reproduced provided acknowledgement is made to the Timber Development Association (N.S.W.) Ltd. Extracts should not be published without prior reference to T.D.A.



# Thermal Properties of Plywood

## Thermal Expansion

Wood (and plywood) expand upon heating as do practically all solids. The thermal expansion of plywood is quite small. The average co-efficient of thermal expansion of plywood is  $4.5 \times 10^{-6} \text{ mm/mm/}^\circ\text{C}$ .

## Thermal Conductivity

The ability of a material to conduct heat is measured by its thermal conductivity, k. The higher the k value, the greater the ability of the material to conduct heat. **The lower the k, the higher the insulation value.** Thermal conductivity varies with timber species, however an average value of  $k=0.1154 \text{ W.m/(m}^2 \text{ }^\circ\text{C)}$  for softwood timbers is sufficiently accurate for determining the overall co-efficient of heat transmission (U value) of a construction assembly.

## Thermal Resistance

The thermal resistance or insulating effectiveness of plywood panels based on  $k = 0.1154 \text{ W.m/(m}^2 \text{ }^\circ\text{C)}$  is  $R = 8.67 \text{ (m}^2\text{.OC)/(W.m)}$ . **The higher the R value, the more effective the insulation.**

For example, the R value for 12 mm plywood =  $(12/1000) \times 8.67 = 0.10 \text{ m}^2 \cdot ^\circ\text{C/W}$ .

Similarly, the R value for 25 mm thick pine plywood is  $(25/1000) \times 8.67 = 0.22 \text{ m}^2 \cdot ^\circ\text{C/W}$ . E

## Thermal Performance of Timber Framed Plywood Clad Walls

Walls with high thermal mass hold substantially more heat thus continue to radiate heat in the evening. In cooler climates, or if the building is to be air conditioned, the addition of insulation to the timber structure can provide equivalent thermal insulation to solid construction.

For example the addition of R1.5 batts into a plywood clad wall with reflective sisalation on 90mm studs will result in a wall with an average R exceeding 2.2 (see Table 2). Therefore, in winter a lightweight timber wall can be a very effective insulator and keep the warmth inside the building.

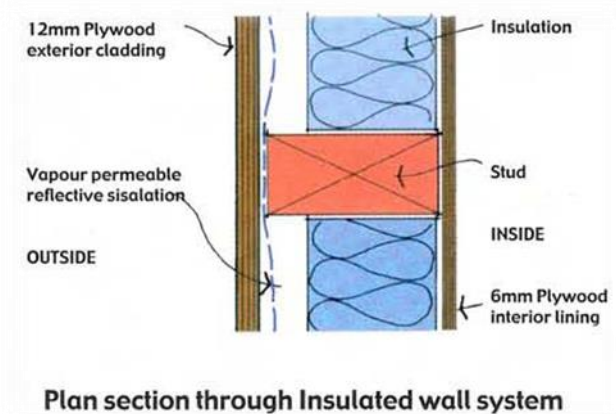

	R Value ( $\text{m}^2\text{ }^\circ\text{C} / \text{Watt}$ )	
	Through Insulated Zone	Through Stud
Outdoor Air Film	0.04	0.04
12mm Plywood Cladding	0.08	0.08
20mm Reflective Air Gap	0.58	
R1.5 Insulation	1.5	
90mm Stud		0.62
6mm Plywood Lining	0.04	0.04
Indoor Air Film	0.12	0.12

Note: As a non-reflective 20mm air gap has an R value of 0.15, an insulated wall system without sisalation would reduce the total R value from 2.36 to 1.93 in the above table.

## Improving Plywood Thermal Performance

Insulation provided by plywood flooring can be further improved by pre-installing or retro fitting a range of commodity or proprietary systems.

The insulation provided by plywood flooring is different in winter (heat flow out) to summer (heat flow in). Other significant factors effecting the “R”-values (a rating system for total thermal resistance of a building element) include floor height above ground, soil type, the relative humidity zone (as defined by the BCA), whether the site is sheltered or exposed, and whether the sub floor is open, partly or fully enclosed. For more detail on R-values please refer to the FWPRDC ([www.fwprdc.org.au](http://www.fwprdc.org.au)) Project No. PR05.1014 report “Insulation Solutions to Enhance the Thermal Resistance of Suspended Timber Floor Systems in Australia”.

The following table provides a guide to the range of some of the possible R-values for plywood flooring. Such situations such as sheltered sites, low set rather than elevated buildings and clay soil rather than sandy soil will increase the calculated R-value for a particular residence.

**Table of Indicative R-values for Plywood Flooring Systems**

Season	Winter (heat flow out)		Summer (heat flow in)	
	Open	Closed	Open	Closed
<b>Sub-floor</b>				
Plywood on joists	0.7 – 0.9	0.9 – 1.8	0.5 – 0.6	0.7 – 1.6
Plywood + U/L + carpet	1.0 - 1.2	1.2 – 2.1	0.8 – 0.9	1.0 – 1.9
Plywood + tiles	0.7 – 0.9	0.9 – 1.8	0.5 – 0.6	0.7 – 1.6
Plywood + ply ceiling under joists	1.1 – 1.2	1.3 – 2.2	0.7 – 0.8	0.9 – 1.8
Plywood + R2 batts between joists	3.0 – 3.2	2.9 – 3.7	2.5 – 2.8	2.7 – 3.5
Plywood + RFL over joists	1.6 – 1.7	1.8 – 2.4	0.8 – 0.9	1.0 – 1.6
Plywood + RFL under joists	1.7 – 1.8	1.9 – 2.5	0.8 – 0.9	1.0 – 1.6
Plywood + Concertina foil between	3.3 – 3.5	2.4 – 3.1	1.3 – 1.3	1.1 – 1.7
Plywood + Air-cell over bearers	1.8 – 1.9	2.0 – 2.6	0.9 – 1.0	1.1 – 1.7
Plywood + 50 mm polyurethane spray under plywood	2.7 – 2.8	2.9 – 3.6	2.5 – 2.6	2.7 – 3.3

Notes:

1. U/L is carpet underlay
2. RFL is used under R2 batts with open sub-floors
3. Wire mesh is used under R2 batts with enclosed sub-floors
4. With higher than R2 bulk insulation adding the increase in R-value to the above R2 value will be indicative
5. RFL is reflective aluminium foil
6. Air-cell is polyethylene & air between aluminium foils

## Exposure to Extreme Heat

For plywood used in typical residential and commercial building applications, the relevant thermal performance criteria are usually based on "fire resistance". However there may be applications where plywood is required to perform under conditions of extreme heat. There is little effect on plywood used in temperatures below 93°C and any strength loss due to temperature is recovered when the temperature is reduced.

Plywood exposed to temperatures in the range 93 to 150°C will undergo slow exothermic decomposition evidenced by charring of the wood surface and weight loss. The rate at which this occurs depends upon the temperature and air circulation. Where the appearance of the plywood is important, it should not be used unprotected in temperatures above 93°C.

In applications involving periodic exposure to temperature ranges from 93 to 150°C, the amount of exposure should be based on the amount of decomposition that can be tolerated before the serviceability requirements of the plywood are impaired. Exposure to temperatures above 150°C will result in increased charring rates and greater possibility of spontaneous combustion if the heat is not dissipated. At temperatures above 200°C spontaneous combustion is probable in a short period of exposure time.

# Technical Explanations

## Critical Radiant Flux

**The Critical Radiant Flux (CRF) test measures the radiant energy required to just sustain burning. It is used in Australia, and in some parts of the USA and some parts of Europe to regulate floor coverings.**

The test involves the product being held horizontally under the influence of a radiant heat source at one end. It is ignited at that end and the radiant heat flux at the point at which combustion ceases is determined. This is the Critical Radiant Flux.

During the test the floor covering is allowed to burn under the influence of the radiant heat source. There is just sufficient air movement in the test chamber to remove the products of combustion into the flue.

## Heat Evolved Index

The heat evolved index relates to the amount of heat released by a burning material, and allows, by its linear scale, distinctions to be drawn between materials on the basis of whether or not the amount of heat evolved from them would be sufficient to cause ignition of nearby combustibles. The higher the index, the more likely is the fire involvement of nearby combustible materials.

## Ignitability Index

The ignitability index relates to the time taken for the volatiles from the test specimens, irradiated at increasing intensity, to form an ignitable gas mixture and be ignited by a small flame. The index is zero if ignition does not occur under the maximum impressed radiation of the heat and could be as high as twenty (20) if ignition occurred within 30 seconds of the test commencement.

## Material Group Numbers

Material Group Number	Description
Group 1	Materials that do not reach flashover following exposure to 300kW for 600 seconds, after not reaching flashover when exposed to 100kW for 600 seconds.
Group 2	Materials that do reach flashover after exposure to 300kW for 600 seconds, after not reaching flashover when exposed to 100kW for 600 seconds.
Group 3	Materials that reach flashover in more than 120 seconds but less than 600 seconds after exposure to 100kW.
Group 4	Materials that reach flashover in less than 120 seconds after exposure to 100kW.

## Smoke Developed Index

The smoke developed index relates to the optical density of smoke produced under the conditions of the standard test. Doubling of the optical density of the smoke increases the smoke developed index by unity. The higher the index, the greater the hazard is likely to be from smoke.

## Spread of Flame Index

The scale of the spread of flame index is based on studies of actual rates of spread of flame on various wall-lining materials. Where the walls of rooms with 2.75m ceiling height were lined with materials with high spread of flame indices, flames rapidly spread up the wall and, by igniting combustible gases that had accumulated below

the ceiling, rapidly involved the whole room in fire. An index of 10 indicates, from the original corner-burn experiments, that the material could be expected to cause flames to reach the ceiling of such a room within 10s of ignition; an index of zero means that the materials will not cause flames to reach the ceiling.

## Steps in establishing a Fire Resistance Level

After a protective layer of char has developed the char rate slows considerably. The charring rate of dry wood has been shown to continue for several hours at a reasonably constant rate given in AS1720.4-2006 by:

$$c = \frac{dh}{dt} = 0.4 + (280/\rho)^2$$

where:

$$c = \frac{dh}{dt} = \text{notional charring rate (mm/minute);}$$

$$\rho = \text{timber density (kg/m}^3\text{) at a moisture content of 12\%}$$

The charring rate of a typical softwood having a density of 500kg/m<sup>3</sup> is 0.76mm/minute. During a fire a realistic assessment of structural response can be made by neglecting 10mm of unburnt wood and assuming the remainder retains its full strength and stiffness.

The effective depth of charring ( $d_c$ ) for each exposed surface after a period of time ( $t$ ) is given by:

$$d_c = ct + 7.5$$

where:

$$d_c = \text{calculated effective depth of charring (mm);}$$

$$c = \text{notional charring rate;}$$

$$t = \text{period of time (minutes)}$$

NOTE:  $t$  can be taken as either the:

- (a) time taken for the FRL to be achieved;
- (b) fire resistance period determined by a series of successive iterations.

The effective residual section is determined by subtracting  $d_c$  from all fire-exposed surfaces of the timber member as shown below :

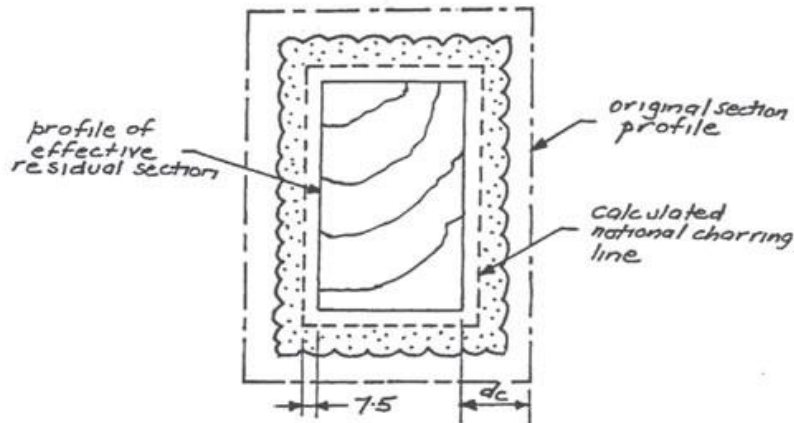

## Revision History

Revision	Changes	Date	Who
6	<ul style="list-style-type: none"><li>• Updated logos and Member lists.</li></ul>	07-02-12	MB
5.0	<ul style="list-style-type: none"><li>• Updated the “Untreated Plywood Table with the latest information sourced from the Timber Development Association of New South Wales.</li></ul>	22-12-09	MB
4.0	<ul style="list-style-type: none"><li>• Clarified the table for the BCA Specifications for Wall and Ceiling Linings.</li><li>• Added a flow chart to aid in determining the specification required.</li><li>• Changed formatting slightly (font – Calibri 10)</li></ul>	22-06-09	MB
3.0	<ul style="list-style-type: none"><li>• Added support for Class 1 and 10 buildings.</li></ul>	17-02-09	MB
2.0	<ul style="list-style-type: none"><li>• Reformatted.</li><li>• Added Hoop pine and Slash pine Material Group Number data sourced from CSIRO reports.</li><li>• Re-ordered some sections.</li><li>• Added a statement that clarifies that as of the 2007 version of the BCA, paint or fire retardants cannot be used to achieve the desired fire hazard properties.</li><li>• Added an additional section to aid in interpreting the BCA.</li><li>• Added an image in Thermal properties section.</li></ul>	20-06-08	MB
1.0	Initial Release	21-11-07	MB

## EWPAA Members

Plywood and Laminated Veneer Lumber (LVL)				
Member Name	Location	Phone	Fax	Web
Ausply	NSW	+61 2 6926 7300	+61 2 6922 7824	<a href="http://www.ausply.com">www.ausply.com</a>
Austral Plywoods Pty Ltd	QLD	+61 7 3426 8600	+61 7 3848 0646	<a href="http://www.australply.com.au">www.australply.com.au</a>
Big River Group Pty Ltd	NSW	+61 2 6644 0900	+61 2 6643 3328	<a href="http://www.bigrivergroup.com.au">www.bigrivergroup.com.au</a>
Carter Holt Harvey Woodproducts Australia (Plywood) – Myrtleford	VIC	+61 3 5751 9201	+61 3 5751 9296	<a href="http://www.chhwoodproducts.com.au">www.chhwoodproducts.com.au</a>
Carter Holt Harvey Woodproducts Australia – Nangwarry LVL	SA	+61 8 8739 7011		<a href="http://www.chhwoodproducts.com.au">www.chhwoodproducts.com.au</a>
Carter Holt Harvey Woodproducts - Marsden Point LVL	NZ	+64 9 432 8800	+64 9 432 8830	<a href="http://www.chhfuturebuild.co.nz">www.chhfuturebuild.co.nz</a>
Carter Holt Harvey Woodproducts (Plywood) - Tokoroa	NZ	+64 7 885 5999	+64 7 885 5614	<a href="http://www.chhwoodproducts.co.nz">www.chhwoodproducts.co.nz</a>
Fiji Forest Industries	FIJI	+67 9 881 1088	+67 9 881 3088	
IPL (West Coast) Ltd	NZ	+64 3 762 6759	+64 3 762 6789	
Juken New Zealand Ltd (Gisborne)	NZ	+64 6 869 1100	+64 6 869 1130	<a href="http://www.jnl.co.nz">www.jnl.co.nz</a>
Juken New Zealand Ltd (Wairarapa)	NZ	+64 6 370 0650	+64 6 370 0653	<a href="http://www.jnl.co.nz">www.jnl.co.nz</a>
Nelson Pine Industries Ltd	NZ	+64 3 543 8800	+64 3 543 8890	<a href="http://www.nelsonpine.co.nz">www.nelsonpine.co.nz</a>
PNG Forest Products Ltd	PNG	+67 5 472 4944	+67 5 472 6017	<a href="http://www.pngfp.com">www.pngfp.com</a>
RH (PNG) Ltd	PNG	+67 5 325 5600	+67 5 325 6165	<a href="http://www.rhpng.com.pg">www.rhpng.com.pg</a>
Valebasoga Tropikboards Ltd	FIJI	+67 9 881 4286	+67 9 881 4154	
Wesbeam Pty Ltd	WA	+61 8 9306 0400	+61 8 9306 0444	<a href="http://www.wesbeam.com">www.wesbeam.com</a>

Particleboard and MDF				
Member Name	Location	Phone	Fax	Web
Alpine MDF Industries Pty Ltd	VIC	+61 3 5721 3522	+61 3 5721 3588	<a href="http://www.alpinemdf.com.au">www.alpinemdf.com.au</a>
Borg Panels Pty Ltd	NSW	+61 2 6339 6111	+61 2 6339 6220	<a href="http://www.borgs.com.au">www.borgs.com.au</a>
Carter Holt Harvey Woodproducts Australia	NSW	1800 891 881	+61 2 9468 5793	<a href="http://www.chhwoodproducts.com.au">www.chhwoodproducts.com.au</a>
D & R Henderson Pty Ltd	NSW	+61 2 4577 4033	+61 2 4577 4759	<a href="http://www.drhenderson.com.au">www.drhenderson.com.au</a>
Laminex	VIC	+61 3 9848 4811		<a href="http://www.thelaminexgroup.com.au">www.thelaminexgroup.com.au</a>
Tasmanian Wood Panels (Aust)	TAS	+61 3 9460 7766	+61 3 9460 7268	
Weatherx Pty Ltd	NSW	1800 040 080		<a href="http://www.weatherx.com.au">www.weatherx.com.au</a>



Visit the EWPAA Website to get the latest information. [www.ewp.asn.au](http://www.ewp.asn.au)  
 Visit [EWPAA Member List](#) to ensure your products carry genuine EWPAA certification